

## NFR NFR Part number 88899204



- Frost formation monitored by temperature probe.
- Choice of defrosting time.

### Part numbers

Type	Code
88 899 204 NFR	88 899 204

### Specifications

Supply voltage	90 ■ 260 V AC 50 / 60 Hz
Maximum frequency variations	± 1 Hz
Choice of total compressor operating time before defrosting (using switch on underside of unit)	25 min, 50 min, 75 min, 90 min
Defrosting time	10 min ± 10 %
Temperature 01	-3 °C
Temperature 02	+18 °C
Probe	KTY - 1 kΩ
Length of temperature probe cable	1,6 m
Absorbed power	36 VA
Weight (g)	155
Relay outputs	1 changeover
Type of contacts	AgNi - cadmium-free
Breaking capacity	2000 VA AC DC ; 80 W
Maximum breaking current	8 V ACDC
Minimum breaking current	10 mA ACDC
Max. breaking voltage	250 VAC
Electrical life (number of operations)	10 <sup>5</sup> at 2000 VA resistive
Mechanical life (operations)	20 x 10 <sup>6</sup>
Terminals	faston type 6,35 mm
Temperature limits (use) according to IEC/EN 60068-2-14 - Casing	0 → +55 °C
Temperature limits (use) according to IEC/EN 60068-2-14 - Probe	-20 → +70 °C
Relative humidity (acc. to IEC/EN 60068-2-30)	93 %
Temperature limits (stored) for casing and probe acc. to IEC/EN 60068-2-1/2	-25 → +70 °C
Degree of protection (IEC/EN 60529) Front face	IP 20
Protection (IEC/EN 60529)	IP 40
Electromagnetic compatibility	IEC/EN 61000-6-2, IEC/EN 61000-6-3
Breakdown voltage according to IEC/EN 60255-5	2,5 kV AC / 1 min / 1 mA / 50 Hz
Insulation resistance (IEC/EN 60255-5)	< 100 M Ω at 500 V DC
Shock resistance according to IEC/EN 60664-1, IEC/EN 60255-5 with the unit switched off	5 kV / wave 1,2 / 50 μs
Insulation coordination	IEC/EN 60664-1

### Operating principle

The NFR defrost relay can be used to optimize the operation of the exchanger in an air-conditioning or refrigeration unit. Compact in size, and with IP20 protection, it is easy to install using screws or by fixing on a DIN rail. The temperature probe supplied with the NFR relay can be disconnected, and should be placed on the exchanger. The standard lengths of the cable between the probe and the NFR relay is 1,6 m. Other lengths are available to order depending on quantity. With a choice of different defrosting times, the unit is easily adapted to the particular installation conditions.

### Principles

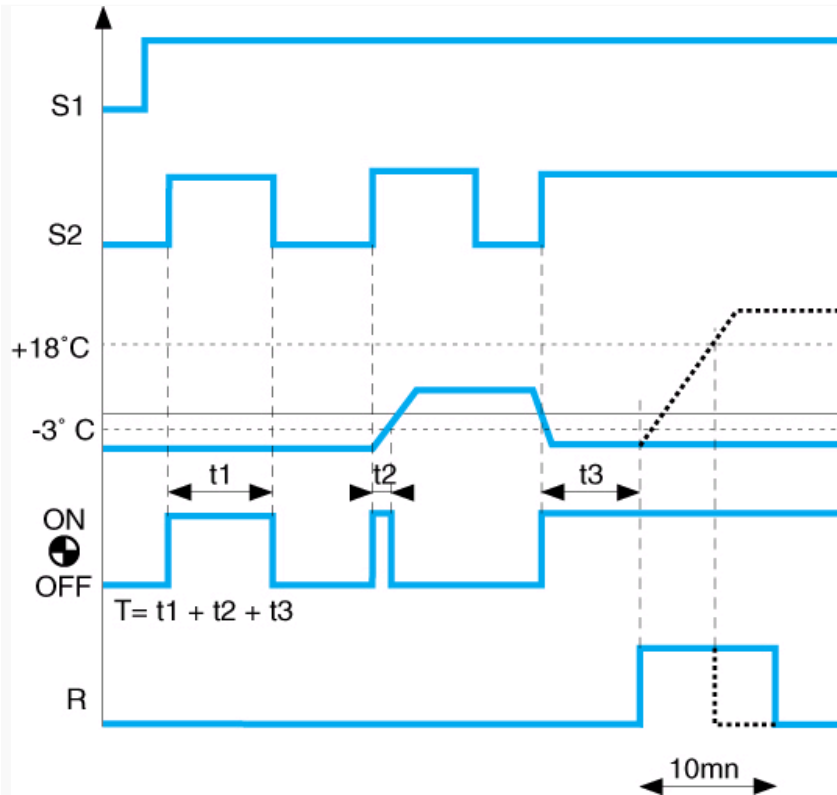

#### Operating principle

The NFR defrost relay can be used to optimize the operation of the exchanger in air-conditioning or refrigeration unit. Compact in size, and with IP20 protection, it is easy to install using screws or by fixing on a DIN rail.

The temperature probe supplied with the NFR relay can be disconnected, and should be placed on the exchanger.

The standard length of the cable between the probe and the NFR relay is 1.6 m. Other lengths are available to order depending on quantity.

With a choice of different defrosting times, the unit is easily adapted to the particular installation conditions.

#### Operating mode

In an air-conditioning system, when the surface temperature of the exchanger between the cooling fluid and the air is too low, frost forms on the surface and the exchanger performs less efficiently. Defrosting is then necessary by reversing the cycle or using heating resistors.

When the total operating time of the set reaches time T (eg : 50 min) while the surface temperature of the exchanger is below O1 (-3 °C), the defrost cycle is determined as time t (10 min). The defrost cycle stops before the end of this time period if the temperature of the cold exchanger exceeds O2 (18 °C).

If pressed for more than 2 seconds, the button on the top initiates a defrost cycle (if the probe temperature is below 18 °C). This stops automatically at the end of 10 minutes or immediately if one of the power supply wires (terminals A1 or A2) or probe wires (terminals Z1 or Z2) is disconnected momentarily.

#### Dimensions (mm)

NFR

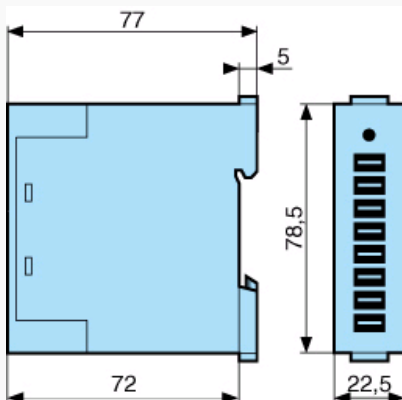

#### Dimensions (mm)

Mounting on DIN rail

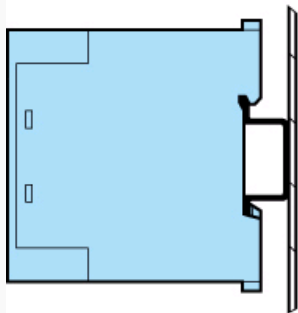

Mounting on DIN rail

**Dimensions (mm)**

on panel using 2 M4 screws

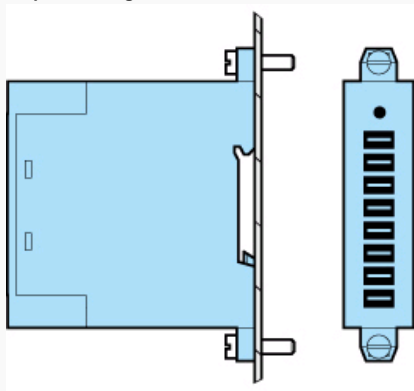

Mounting on panel using 2 M4 screws

**Connections**

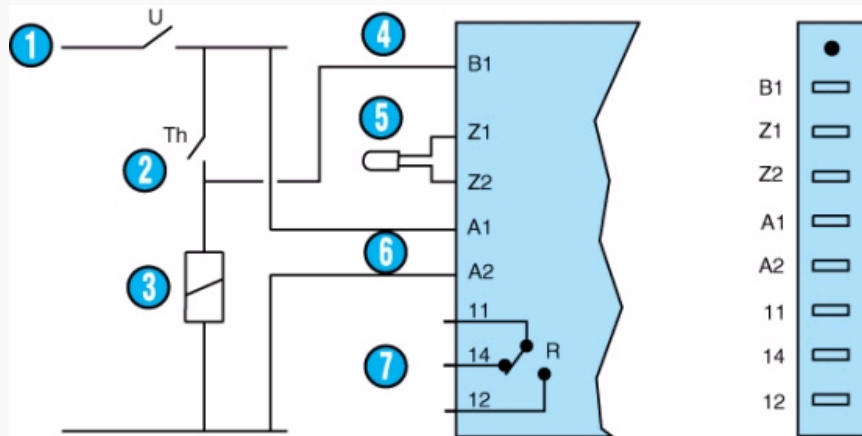

N°	Legend
1	Auxiliary power supply contact
2	Compressor control thermostat
3	Compressor contactor coil
4	Compressor control
5	Probe
6	Power supply
7	Defrost control